



# **E-Skylight, Inc.**

**Skylight  
Installation & Maintenance  
Manual  
For  
Factory Assembled Polygon Skylights**

**E-Skylight, Inc.  
PO Box 830  
Branford, CT 06405  
Tel. (866) 624-3759  
Fax. (207) 636-8004  
[www.e-skylight.com](http://www.e-skylight.com)**

# **IMPORTANT NOTICE:**

**PLEASE READ THE ASSEMBLY INSTRUCTIONS THOROUGHLY PRIOR TO BEGINNING SKYLIGHT INSTALLATION. FAILURE TO COMPLY WITH ALL ASSEMBLY INSTRUCTIONS AND PROCEDURES WILL VOID THE WARRANTY AND MAY RESULT IN PERSONAL INJURY OR DEATH.**

## Table of Contents:

	<b>Page #</b>
<b>General Installation Guidelines</b>	<b>4</b>
General Notes	4
Safety	4
Material Storage	4
Material Handling	5
Job Site	5
Weather Conditions	5
<b>Tools Required</b>	<b>6</b>
Materials Not Included	6
<b>E-Skylight Components</b>	<b>7</b>
Base Plates / Sills	7
Rafters / Purlins	8
Hips / Ridges	9
Caps / Closures / Misc.	10
Hardware	11
<b>Exploded View of Typical Pyramids</b>	<b>13</b>
<b>Step By Step Assembly Procedure</b>	<b>14</b>
<b>List of Appendicies</b>	<b>20</b>

## **General Installation Guidelines:**

### **General Notes:**

1. Please familiarize yourself with your shop drawings prior to receiving your skylight and have your shop drawings (8.5" x 11" details included with your order) available when installing your skylight.
2. The hardware referenced in this manual is also referenced in your detail package. Please be sure to use the correct fasteners and sealants to insure quick and easy assembly and to insure proper performance of your skylight.
3. Actual components on your skylight may vary based upon the skylight size and design. See detailed shop drawings for actual extrusions and hardware used on your skylight. Components which may vary are referred in the installation instructions as well as the piece mark drawings as "xxx" components. For example, a sill extrusion referred to as "Sxxx" on assembly diagrams may be a S201, S401 or S501 depending on the specific requirements for your skylight and are clearly marked on your shop drawings.

### **Safety:**

Skylight installation generally involves working on a roof near an opening in the roof, and is therefore inherently dangerous. There are risks of personal injury to oneself by falling, or to others on the ground by falling material, tools, or supplies. Before attempting any skylight installation obtain all personal safety protection equipment in accordance with OSHA guidelines. Whenever working on the roof you must always tie off using this equipment to ensure your personal safety. Always wear a full-length shirt, pants, gloves, and hardhat to protect against the potential of cuts from sharp edges of metal or glass.

### **Material Storage:**

Material should be kept at a convenient but, safe distance from the roof opening and on a flat secure surface. This is a safety issue as you can lose your balance stepping on or over poorly located materials. Materials not stored on a flat and secure surface can easily fall off the roof causing a safety risk to you and others.

**Material Handling:**

Handling of skylight materials is a safety concern. It is important to have sufficient personnel, and or equipment available to handle the skylight components. For example, the aluminum frame components can be long, heavy, and awkward for movement by only one person. They can also have sharp edges from machining. Glass requires special equipment for safe handling due to its weight and fragility. Glazing cups should be used to move or set all glass. For larger pieces, those exceeding 15 square feet, a crane or other lifting device is recommended. When installing pre-assembled units a crane is strongly recommended. See GANA manual (Appendix "B") for other suggested equipment.

**Job Site:**

For a safe and efficient skylight installation, tools and materials must be kept in neat order. Packaging materials, used rags, tools, hardware etc., should all be promptly and properly disposed of to ensure personal safety, the safety of others and to protect against roof punctures or skylight damage.

**Weather Conditions:**

Weather conditions have an important impact on the safety and effectiveness of your skylight installation. Do not attempt a skylight installation under adverse weather conditions:

**Tools Required:**

Safety Glasses  
Chalk Line  
Drill and Drill Bits (Std, Phillips & Square)  
Wrenches  
Pop Rivet Gun  
Electric Screw Gun  
Caulking Tools  
Utility Knife  
Glass Scraper  
Claw Hammer

Framing Square  
Socket Set  
Tape Measure  
Caulking Gun (10.3 oz tubes)  
Electric Drill  
Rubber Mallet  
Level, Transit  
Sheet Metal Snips  
Glass Cups  
Pry Bar

**Materials Not Included With Skylight:**

Curb Construction/Material  
Rags/Cleaning Towels  
Masking Tape

Roofing Material  
Glass Cleaner  
Isopropyl Alcohol

# E-SKYLIGHT COMPONENTS

## (Sills and Base plates)

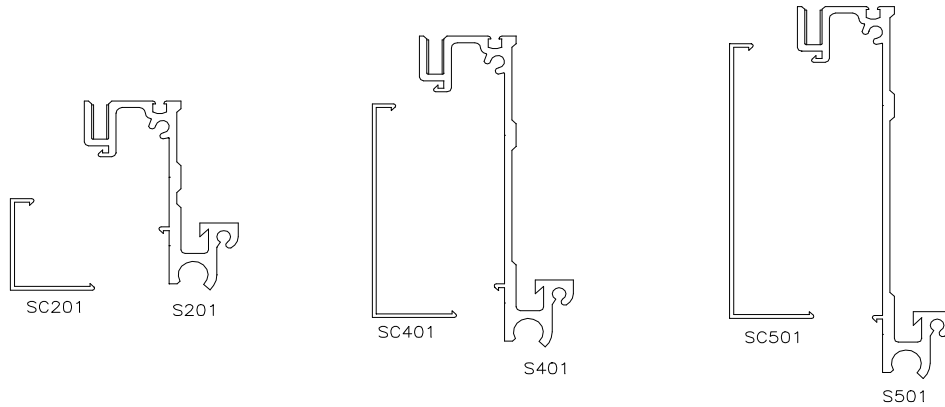

SILLS / SILL COVERS



BASE PLATES

# E-SKYLIGHT COMPONENTS

(Rafters, Mullions and Purlins)

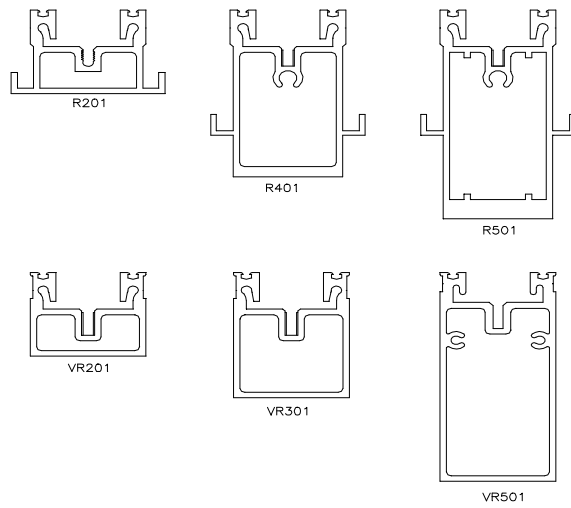

RAFTERS / MULLIONS

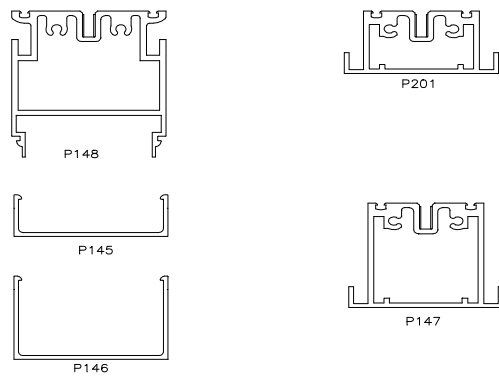

PURLINS



# E-SKYLIGHT COMPONENTS

## (Hip Rafters and Ridges)

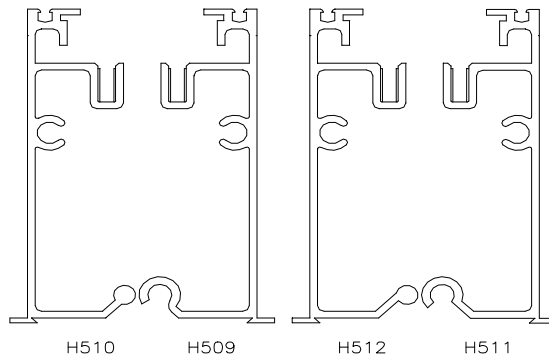
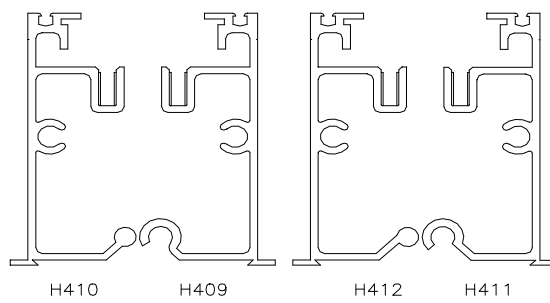
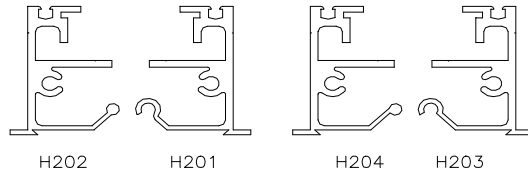

HIPS / RIDGES

# E-SKYLIGHT COMPONENTS (Miscellaneous Extrusions)

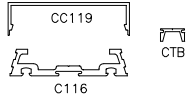

CAPS / CLOSURES

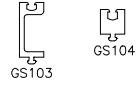

ADAPTORS

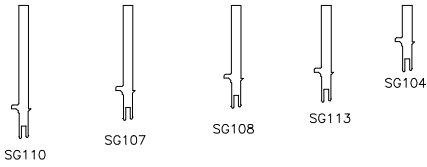

GLAZING SUPPORTS

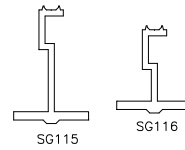

CAP STEMS

# E-SKYLIGHT COMPONENTS (Hardware)

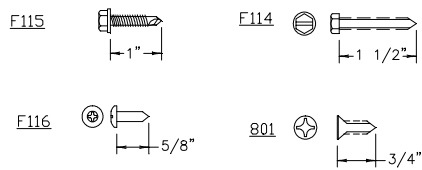
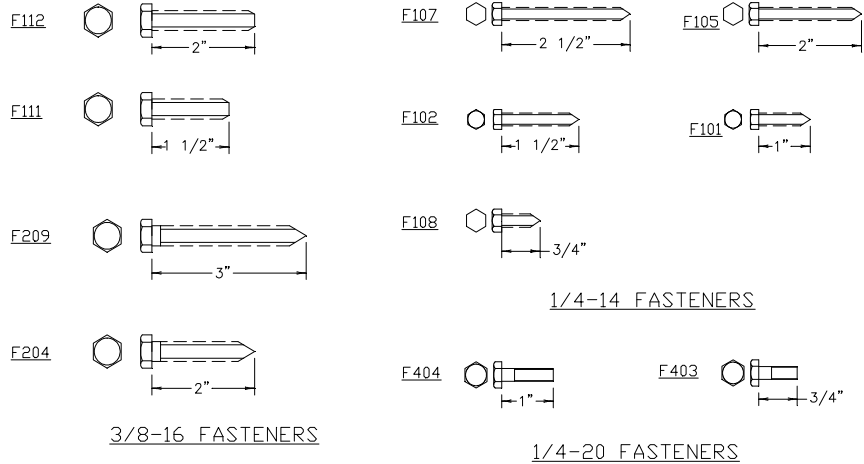

MISC FASTENERS

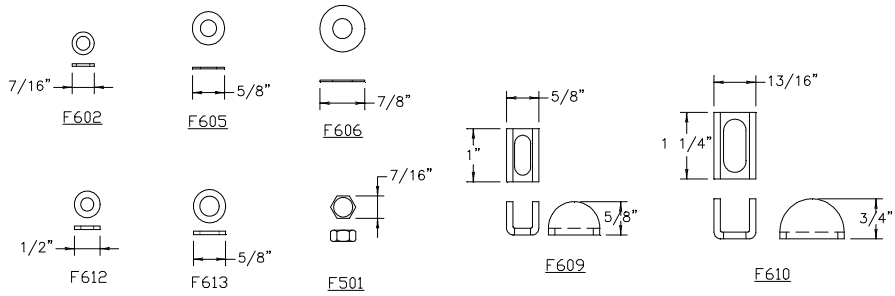

WASHERS AND NUTS

# E-SKYLIGHT COMPONENTS (Hardware)

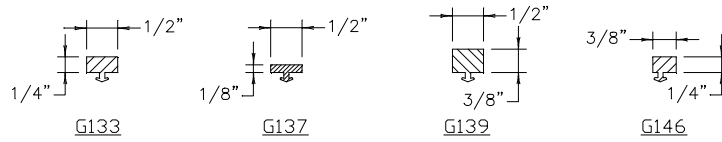

GASKETS

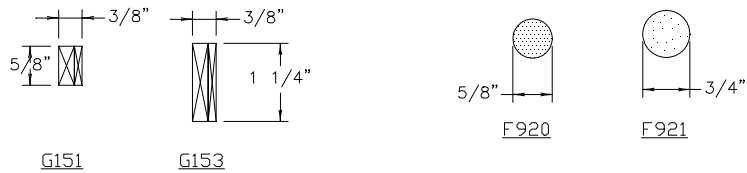

GLASS SETTING BLOCKS

BACKER RODS

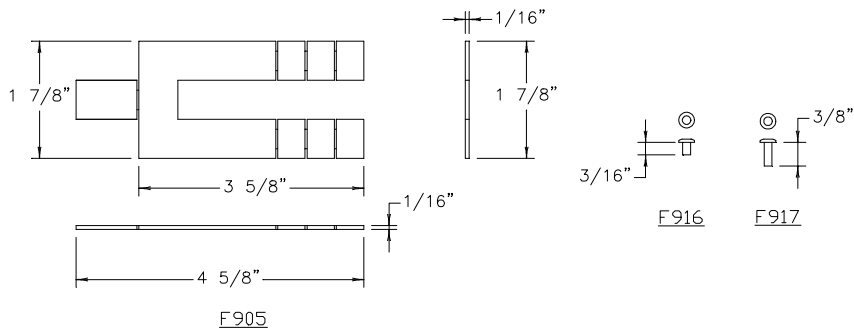

SHIM

POP RIVETS

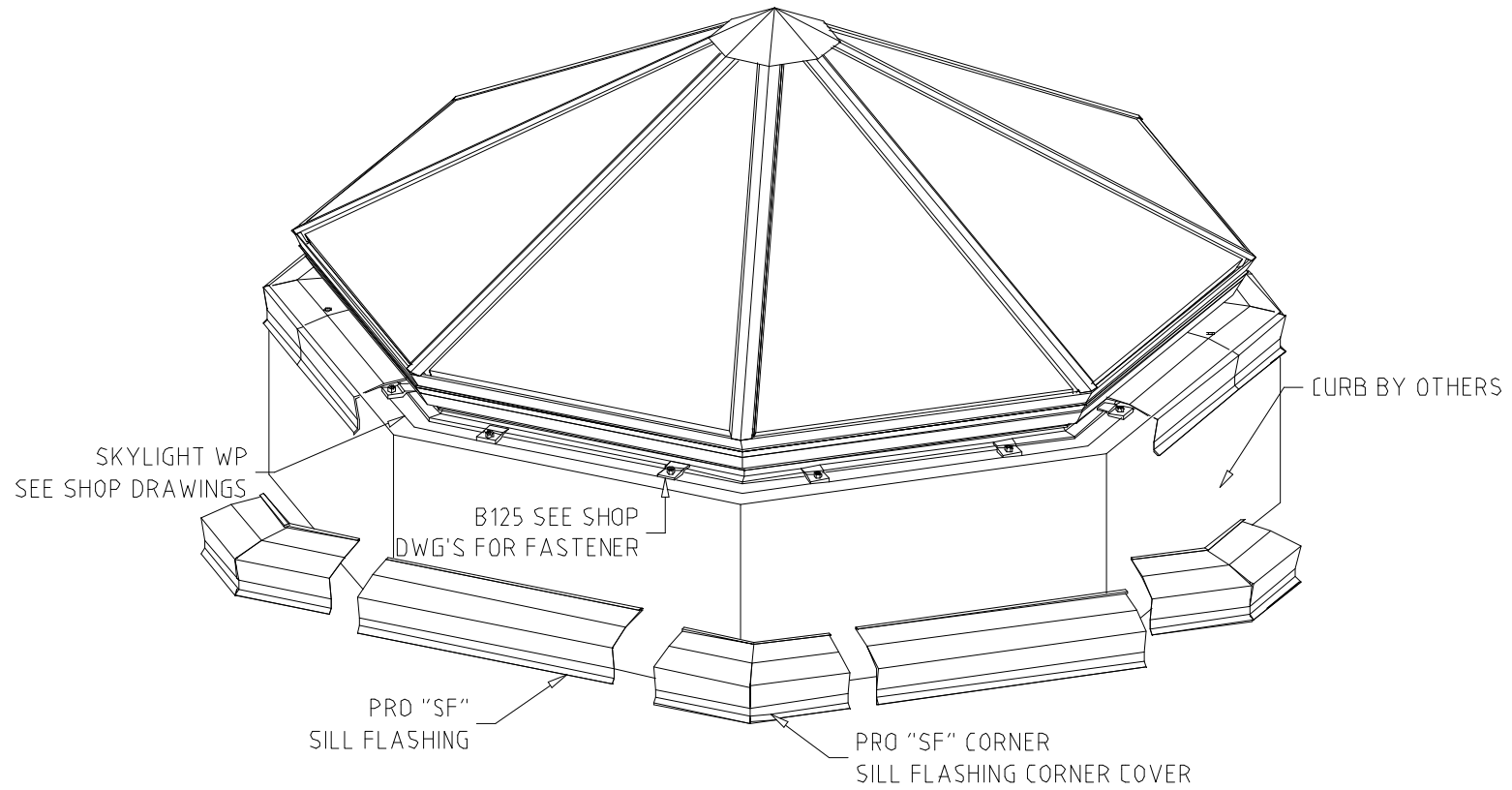

**Exploded View of Factory Assembled Polygon**

## **Step by step Assembly Procedure:**

### **STEP #1: Curb Layout**

The curb construction must be verified as sufficient to withstand the design loads imposed by the skylight and weather conditions. Please note that the standard design loads are listed on detail pages of your shop drawing set. E-Skylight.com, Inc. cannot be held responsible for the installation of a skylight on a curb that does not meet or exceed these design criteria. This verification by the skylight purchaser and installer with the curb manufacturer is essential to ensure proper installation as an under designed curb is a safety and performance problem.

The curb must be accurately measured for proper dimensions, squareness, and levelness prior to installation. This is required to ensure ease and accuracy of installation as well as future performance. Measure the actual curb dimensions to determine if your skylight will fit or if the curb will require modifications. Check the diagonal measurements of the curb for squareness. Use a laser level or a transit to locate the "high spot" on the curb. The shimming of all points of attachment are based on the difference in elevation from this point. Note that shimming cannot exceed 1/2", so curbs with a variation in excess of this amount must be modified prior to attaching the skylight.

1. Measure curb dimensions prior to beginning installation. Check dimensions of finished curb for level as well as dimensional accuracy. Curb must be within 1/2"± of level and perimeter dimensions must be within 1/8"± of specified curb dimensions (See Diagram #1 & Shop Drawings).

2. Check dimensions of curb from corner to corner and from flat to flat. This should be done at the outside to outside points of the finished curb “out to out of curb” (see Diagram #1).

**IMPORTANT NOTE:**

***Curb must be symmetrical for skylight to fit properly!!!***

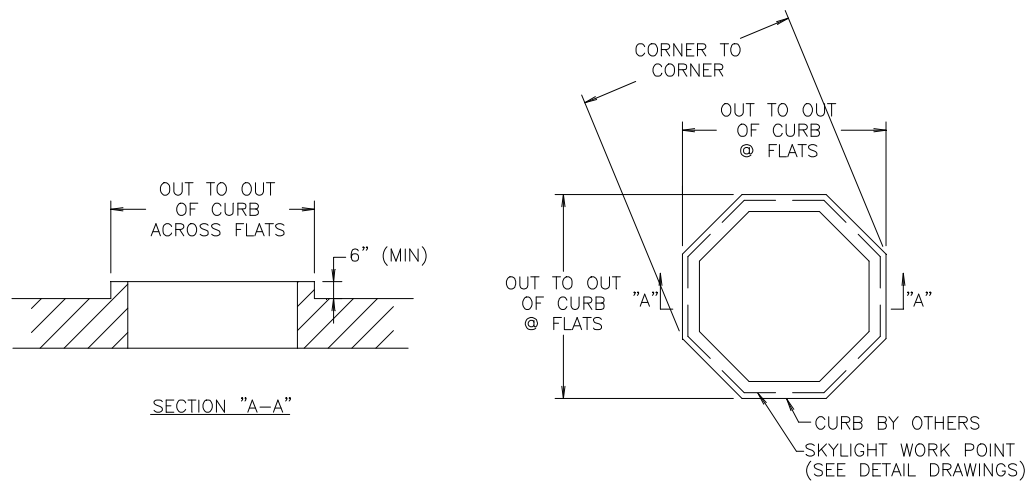
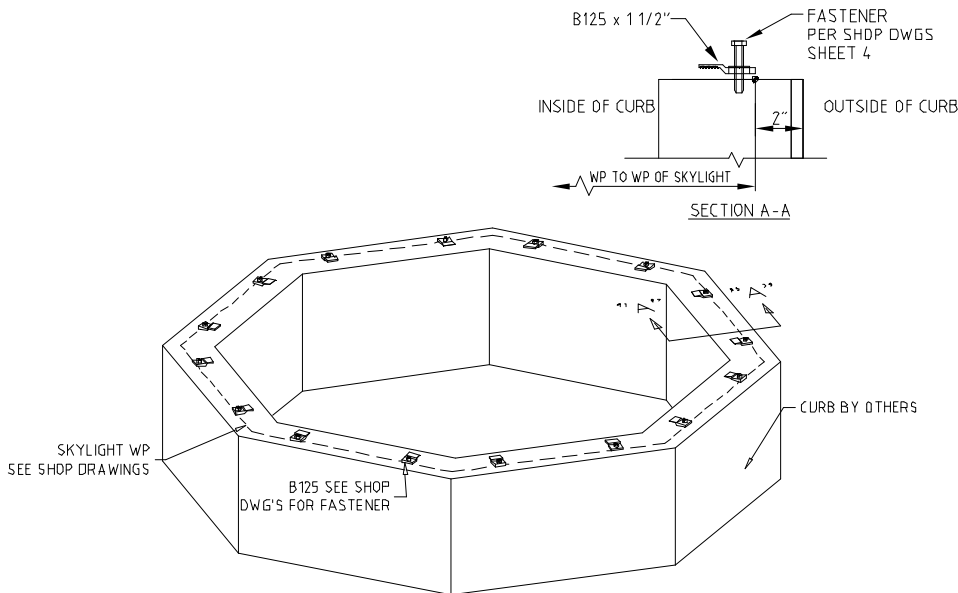

Diagram #1 – Checking Curb Dimensions

**STEP #2: Anchoring Skylight to Curb**

Remove the skylight and anchoring hardware from the packaging materials. **Reuse the anchor components (B125) on the roof curb.** **Do Not Use the Wood Shipping Curb as part of the permanent installation.** The skylight is anchored to the curb by attaching the base plate clips (B125) to the curb with the fasteners provided (see Diagram #2 thru 2B). Note: do not tighten fasteners at this time. Leave 1/4" +/- so clips can be rotated to the side for clearance.



**Diagram #2 – Attaching base plate clips**

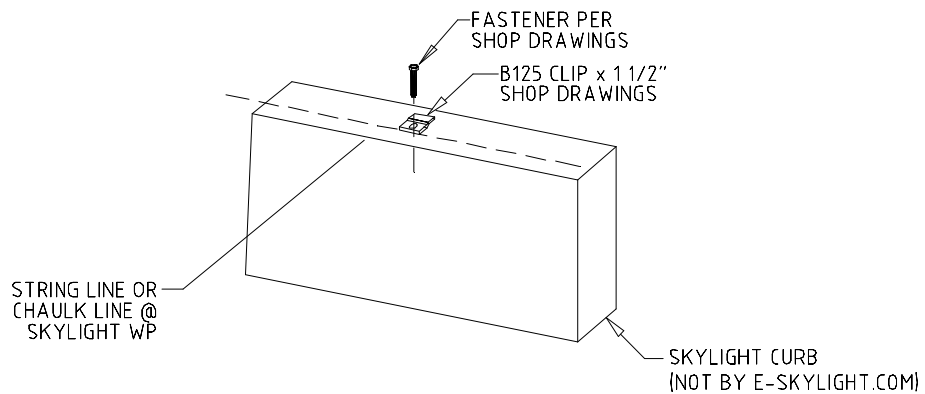

**Diagram #2A – Attaching base plate clips**



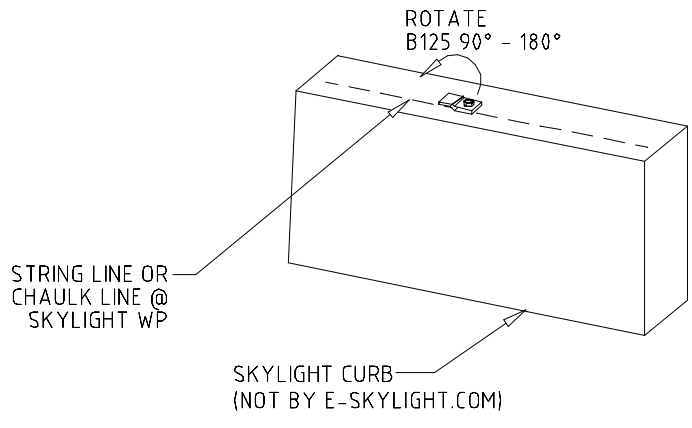

Diagram #2B – Rotating base plate clips

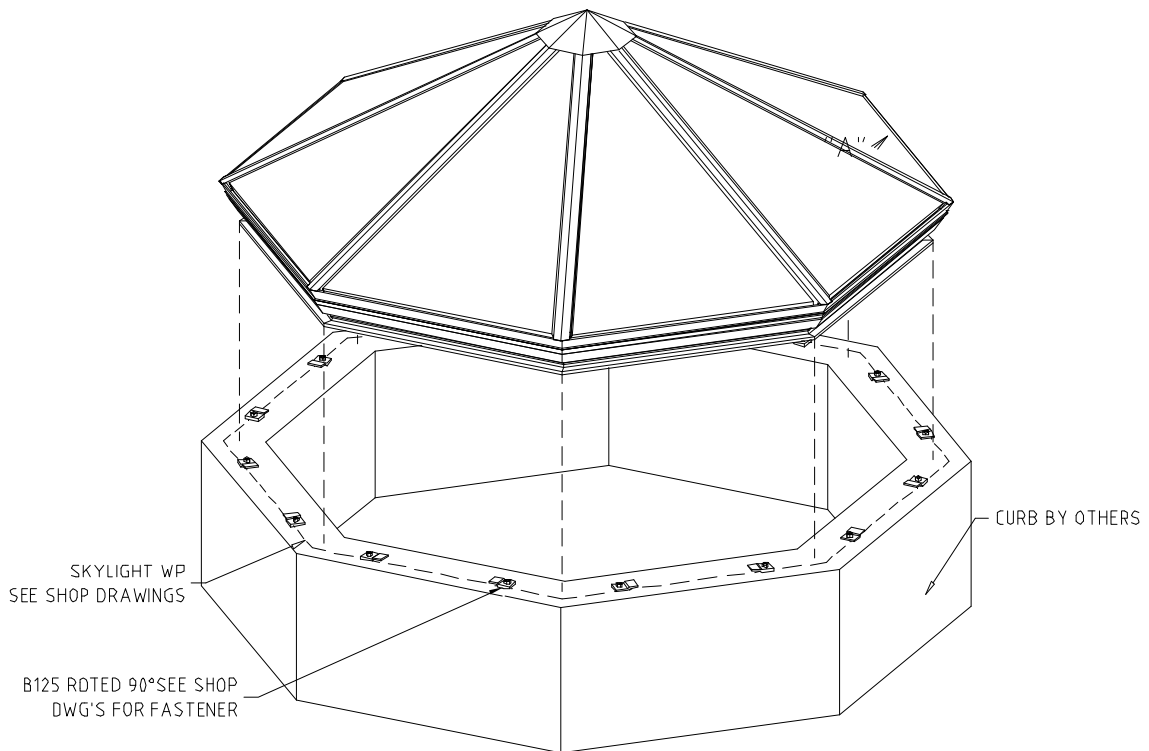

Diagram #3 – Setting pre-assembled skylight in place

### **STEP #3: Securing Skylight to Curb**

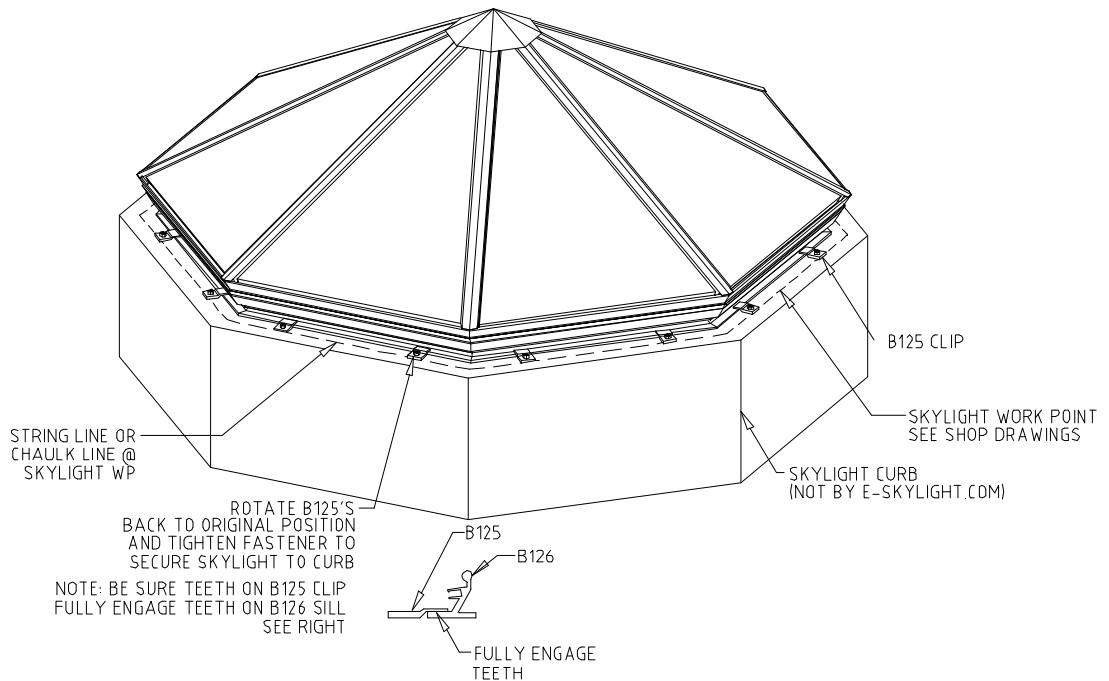

Diagram #4 – Securing skylight to curb

### **STEP #4: Flashing**

Note: Remove all protective plastic coatings from finished face of metal flashings prior to installation of flashing.

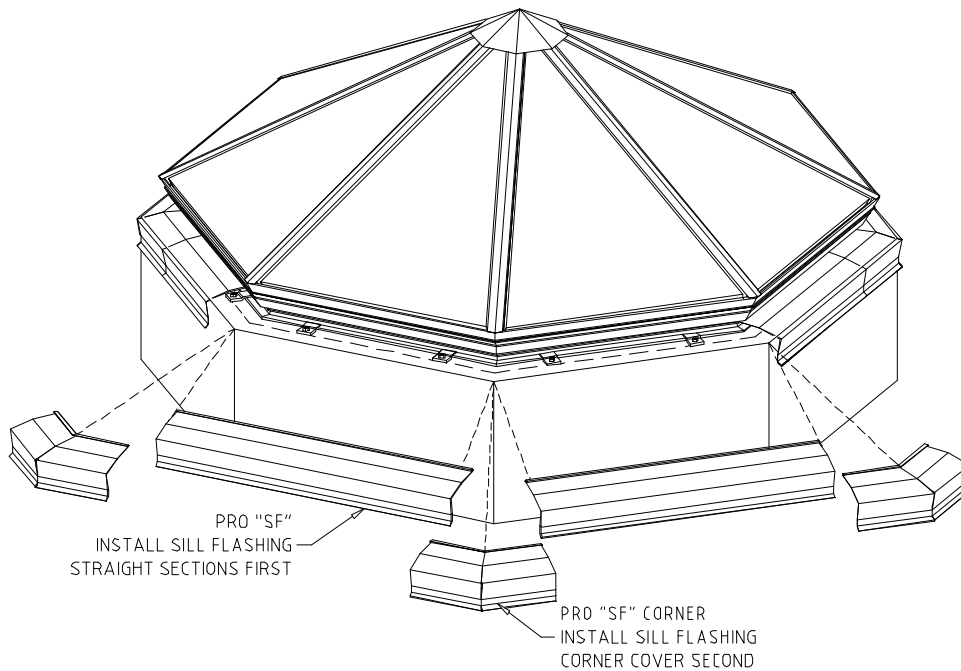

Diagram #5 –Sill Flashing

1. Snap-in perimeter flashing (Pro "SF") as shown on shop drawings sheet 4 (See Diagram #5).

2. Install Sill Corner Cover using colored silicone (to match finish of skylight).  
(See Diagram #6)

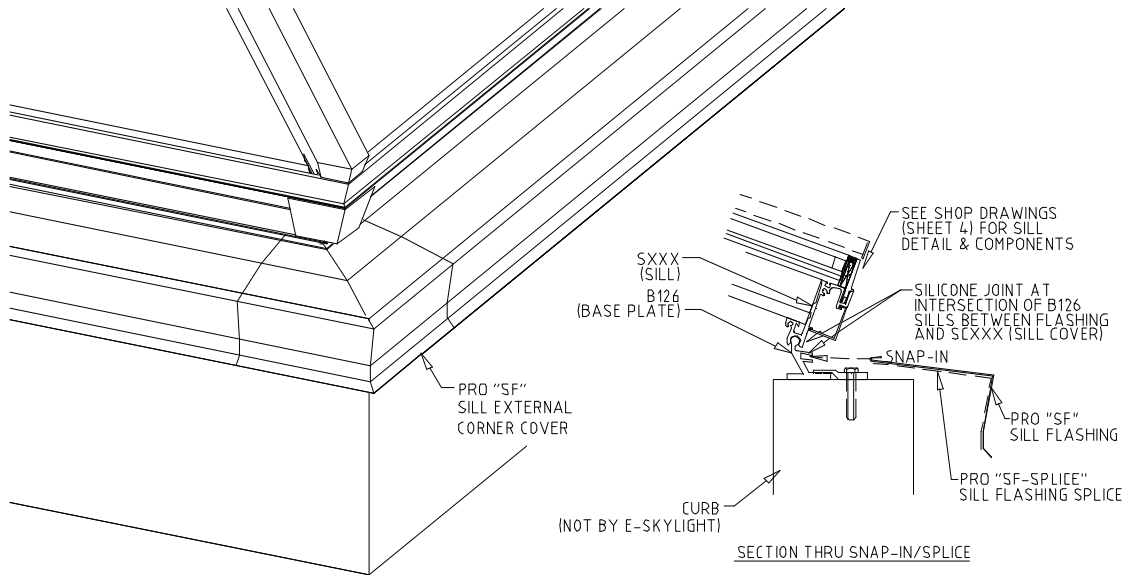

Diagram #6 – Corner Splice

# **LIST OF APPENDICIES**

**APPENDIX “A”**

**DOW CORNING 795  
BUILDING SEALANT**

**APPENDIX “B”**

**CLEANING AND  
MAINTENANCE GUIDE**